



SUA-110H28x-x-S175

SHELL :

Blank : BRASS

I : SPCC

COLOR :

Black: B

White : W

SPECIFICATIONS

Electrical:

- 1.Current Rating: 1.5A / contact terminal
- 2.Voltage Rating: 30V DC
- 3.Contact Resistance: 30 mΩ Max
- 4.Dielectric Withstanding Voltage: 500 V AC AT Sec Level
- 5.Insulation Resistance: 1,000 MΩ Min

Mechanical:

- 1.Connector Mate and Unmate Force
Mate force: 3.57 kgf (Max)
Unmate force: 1.02 kgf (Min)
- 2.Terminal Retention: 1.2 kgf (Min)

Material:

- 1.Housing: PBT,UL 94V-0
- 2.Contact: BRASS
- 3.Shell: BRASS / SPCC

Finish:

- 1.Contact: Plated Gold in Mating Area ;
Tin Plated on Solder Balls ;
Nickel under plated overall
- 2.Shell: Nickel under Plated surface layer

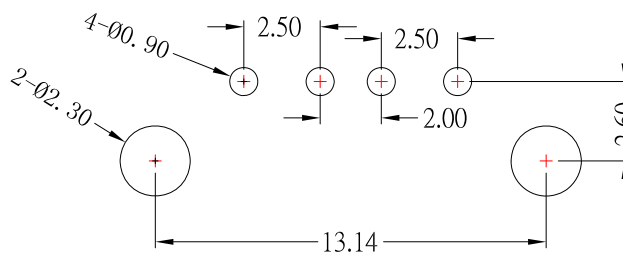
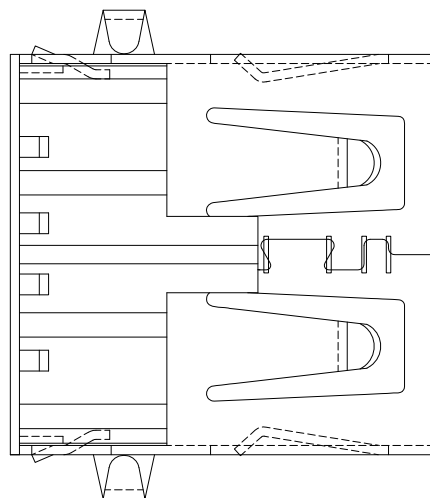
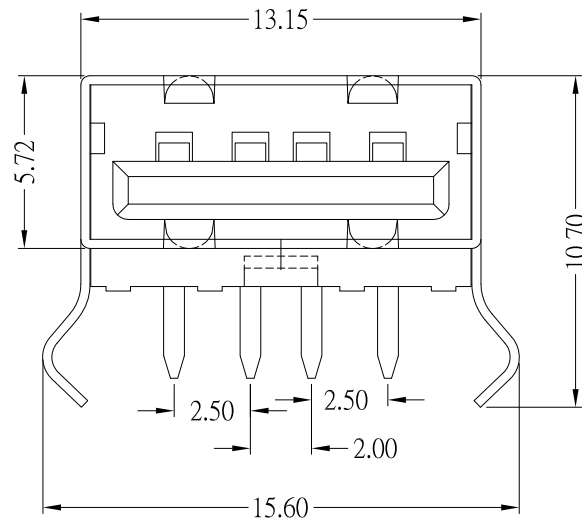
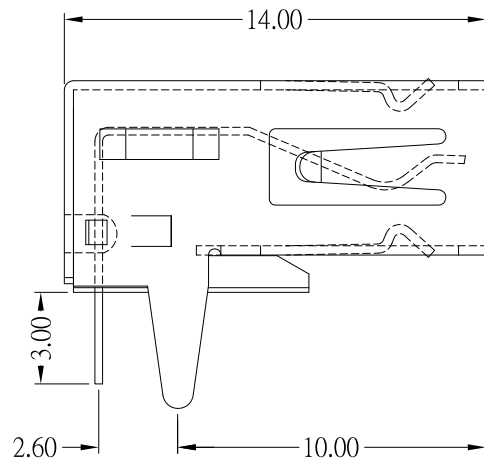

P.C.B LAYOUT MOUNTING PATTERN



TOLERANCE UNLESS OTHERWISE STATED:
 Up to 5 ±0.2
 Above 5 ~ 15 ±0.3
 Above 15 ~ 30 ±0.4
 Above 30 ~ 50 ±0.5
 Angle ±0.3

3RD. ANGEL'S



UNITS MM

DRAWN BY:	DATE	MAT'L	TITLE	CONNECTOR
Jack Lu	06/15/15			
CHECKED BY:	DATE	FINISH	MODLE	USB AF DIP 90度 無捲邊膠芯反向
Jacky Chen	06/15/15			
APPROVED BY:	DATE	SCALE	DWG NO.	SUA-110H28x-x-S175
Tony Kao	06/15/15	1 : 1	PART NO.	SUA-110H28x-x-S175
		SHEET NO.	1 of 1	SIZE A4
				VER R2